



# 1 million reasons to choose the best

Danfoss AB-QM – Perfect control and balance in one valve. More than 1 million AB-QM valves are installed

worldwide making the Danfoss PICV a safe and energy saving choice.

**3 years**  
payback time

Case studies prove that investing in Danfoss PICV's has a payback of less than 3 years.





# CREATED TO MEET YOUR LOCAL NEEDS EVERYWHERE

## From new-construction to renovation – made for your business

Despite all the innovations in water based HVAC systems, it is still a challenge to balance and control a HVAC system without pressure independent technology. The Danfoss PICV will help save time during implementation, decrease maintenance and save energy whether you're looking for a solution during renovation or designing for a new building.

## The easy choice

The following three sections describe typical situations for PICV. In each section you will find plenty of reasons to choose the best. **Danfoss AB-QM.**



# I ALREADY USE PICV – WHY DANFOSS?

## There are some other types of PICV – and then there's the AB-QM

Danfoss is the market leader in pressure independent technology and has the most experience in producing reliable and precise automatic solutions. Independent research institutes determined that the AB-QM provides the best control performance compared to other pressure independent control valves on the market. With our extended product range of valve sizes and flow capacities coupled with matching actuators, we offer you perfection in control, even at low flows.

To make your job easier, our experienced sales and support staff will recommend the best setup for your application and provide you the best service possible.

## Your benefits:

Best control performance, broad product range with unique actuators, experienced customer support.





# I USE CONVENTIONAL SOLUTIONS – WHY CHANGE?

## The future is now

Comparing Danfoss PICV to conventional two-way valves and manual balancing valves, you will simply need fewer products. The AB-QM is a compact automatic balancing and pressure independent control valve in one. That implies less commissioning and installation time; it will make calculations easier and manual balancing of the installation is unnecessary. The only thing you have to do is select the required flow and the AB-QM will automatically balance the installation.

## Your benefits:

Fewer devices and potential leak points, less commissioning and installation time; and a building balanced to load conditions at all times.



# I HAVE AN EXISTING INSTALLATION – WHY UPGRADE?

## AB-QM is perfect for upgrading your current HVAC system

From experience we know that our customers are challenged with balancing and control issues in their existing HVAC installations. Equipping your system with AB-QM will help you solve them. Since AB-QM will also save you energy, your investment will be paid back in less than 3 years.

## Your benefits:

Improved balance and control, improved indoor comfort, and payback in less than 3 years.

# PERFECT CONTROL AND BALANCE WITH AB-QM

Danfoss has developed the AB-QM, a pressure independent balancing and control valve in one. This valve, combined with a Danfoss actuator, optimizes your system in a cost-effective manner, saves energy and enables a perfect indoor climate.

## Peace of mind

More than 1 million AB-QM valves installed really says it all. This valve offers more than just control and balance in HVAC systems. It will save you time when installing, calculating and commissioning.

Your customers will benefit from better comfort and energy savings.

## Your benefits:

Lower costs and higher energy efficiency.



# FULL RANGE FROM 1/2" TO 10"

The AB-QM pressure independent control valve (PICV) was introduced a few years ago and enjoyed significant success, as our long list of references and success stories shows. The Danfoss AB-QM is available in connection sizes from 1/2" to 10".

To perfectly match all sizes of AB-QM valves, Danfoss has developed a unique collection of actuators. This excellent combination of AB-QM and actuator can handle any size of application.



## Your benefits:

Extensive PICV size and actuator choice.

# AB-QM HELPS YOU GO GREENER

“ With AB-QM valves, we have saved a significant amount of electricity (14-15%) simply by regulating the chilled water pump flow via variable speed drives at required rate only. Not only does this benefit us in terms of financial costs, it also supports the company’s long term sustainable environment policies.”

**Edward Kway – Head of Engineering  
Fraser Centrepoint**



## WE’VE DONE THE MATH SO YOU CAN FOCUS ON ENERGY SAVING AND COST REDUCTION

Controlling indoor temperatures is the central function of a HVAC installation. Therefore the control valves are crucial and they need to be accurately sized to achieve optimal working conditions. The AB-QM eliminates the need for sizing calculations for control valves.

With AB-QM there is no need to calculate the Cv value of the valve anymore because if the required flow is within the setting range it can be applied. This also means greater flexibility because several different sizes of AB-QM can be used to realise the same flow. The simple setting procedure

of the AB-QM makes late changes in the design or subsequent system refits easy to implement.

The AB-QM has a compact and unique design that ensures 100% authority with all flow settings at a wide variety of differential pressures and therefore makes authority calculations unnecessary. Having a 100% valve authority increases the control quality and precision – also at low flow requirements. This creates a better comfort in the building, as well as energy savings.

### **Sizing**

To properly size a traditional 2-way control valve, it is necessary to know the required flow rate, pump head and the resistance in the rest of the system. With AB-QM you only need to know the required flow rate. Simply select an AB-QM valve where the required flow is within the valves flow range. The AB-QM valve will save you a lot of time.

### **Your benefits:**

Easy setting and sizing, 100% authority and perfect control.



# HOW DOES IT WORK?

The working principle is as simple as it is effective. The AB-QM consists of two different parts: the control valve (orange) and the differential pressure controller (blue). The integrated membrane of the pressure controller maintains a constant differential pressure across the valve. The flow through a valve is determined by the Cv value and the differential pressure across the valve.

Because the differential pressure is now constant, overflows are prevented and the authority of the AB-QM to control the flow is ensured.

will immediately be pushed down and close the pressure controller (2). If the differential pressure decreases, the membrane will instantly move up again (3).

## Figures 1-3

In the illustrations you can see the membrane in action. If the differential pressure across the valve increases, the membrane

## Your benefits:

Constant  $\Delta p$  across the control valve, resulting in accurate flow limitation and 100% authority.



# APPLICATIONS

The Danfoss AB-QM is the obvious choice of a control valve for water based terminal units, such as Air Handling Unit, Fan-coil unit, chilled beams or one-pipe radiator systems. The AB-QM combined with a Danfoss actuator, ensures the required flow in every unit and maintains hydronic balance in the system. AB-QM is successfully applied in offices, hotels, hospitals, airport terminals, and in buildings where accurate temperature control is extremely important, such as in laboratories or food processing facilities.

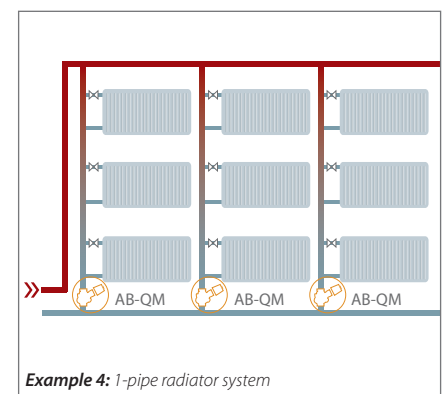
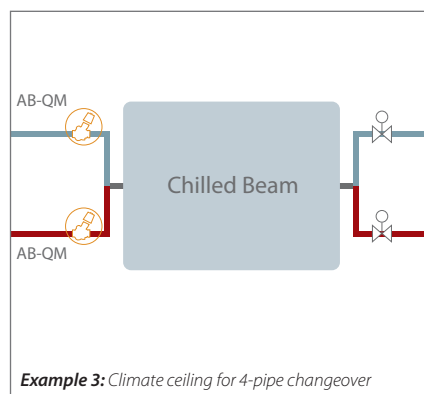
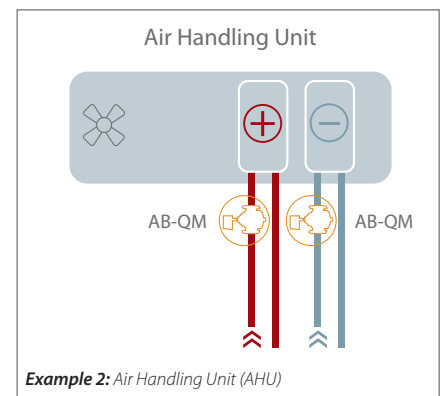
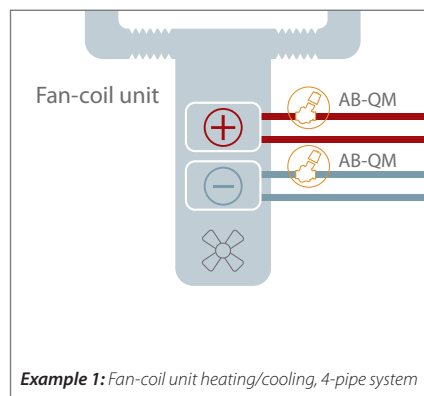

# THE PERFECT MATCH

Danfoss offers a wide range of actuators that match with the AB-QM. We can provide actuators suitable for all control strategies. On/Off, 3 Point (floating) and modulating.

Our gear actuators have advanced stroke-length detection to ensure full control from 0-10 Volt. Therefore we recommend Danfoss actuators for perfect proportional control.

## A selection from our extensive range of actuators:



### TWA-Z

Thermal wax actuator On/Off NC/NO.

### ABNM LOG/LIN

Modulating thermal actuator 0-10V.

### AME/V 110/120 NL

Motorized actuator for 3-point or modulating (0-10V) control.

### AME 15QM

Motorized actuator for 3-point or modulating (0-10V) control.

### AME 55QM

Motorized actuator for 3-point or modulating (0-10V) control.

### AME 85QM

Motorized actuator for 3-point or modulating (0-10V) control.



Learn more on our website [ABQMvalves.com](http://ABQMvalves.com)

# AB-QM Projects



**Rochester Institute of Technology**  
Rochester, NY



**NREL Energy Systems Integration Facility**  
Golden, CO



**Georgia Institute of Technology**  
Atlanta, GA



**University of Missouri Hospital**  
Columbia, MO



**University of California - Irvine**  
Irvine, CA



**Toledo Hospital**  
Toledo, OH

These are just a few of the places where the AB-QM valve is already being used. Contact Danfoss to find out more about how the AB-QM valve can help you on your next project.



Danfoss can accept no responsibility for possible errors in printed materials and reserves the right to alter its products without notice. All trademarks in this material are property of the respective companies. Danfoss and Danfoss logotype are trademarks of Danfoss A/S. All rights reserved.



**Danfoss**  
Toronto / Baltimore  
Tel.: 1-866-375-HVAC (4822)  
Fax: 905-285-2056  
[www.ABQMvalves.com](http://www.ABQMvalves.com)