



MULTI

12,000 BTUH Multi-zone Floor Ceiling

**Model:
KM12HTDI**



Item	Unit	Specification
Model	—	KM12HTDI
System and Electrical Ratings		
Rated Cooling Capacity	Btu/h	11946
Rated Heating Capacity	Btu/h	13,140
Sound Pressure (High/Low)	dB(A)	40/36
Air Flow (max)	CFM	382
Normal Operational Voltage	—	208-230 V, 1 Ph, 60 Hz
Voltage Range	V	187-253
MCA/ Power Cable Size	A	1
Unit and Pipe Data		
Communication Cable Wire Size	AWG	14-4
Unit Dimensions (L×H×D)	mm	1220 x 700 x 225
	Inch	48.0 x 27.5 x 9.0
Weight (Net/Shipping)	lbs	88/110
Drain Size (OD)	mm	17
	Inch	0.67
Refrigerant Type	—	R410A
Gas Pipe Size (OD)	Inch	3/8
Liquid Pipe Size (OD)	Inch	1/4
Connection Method	—	Flared

Job Name:

Schedule Reference:

Date:

Specification are subject to change without notice.



Outline and Physical Dimensions of KM12HTDI.

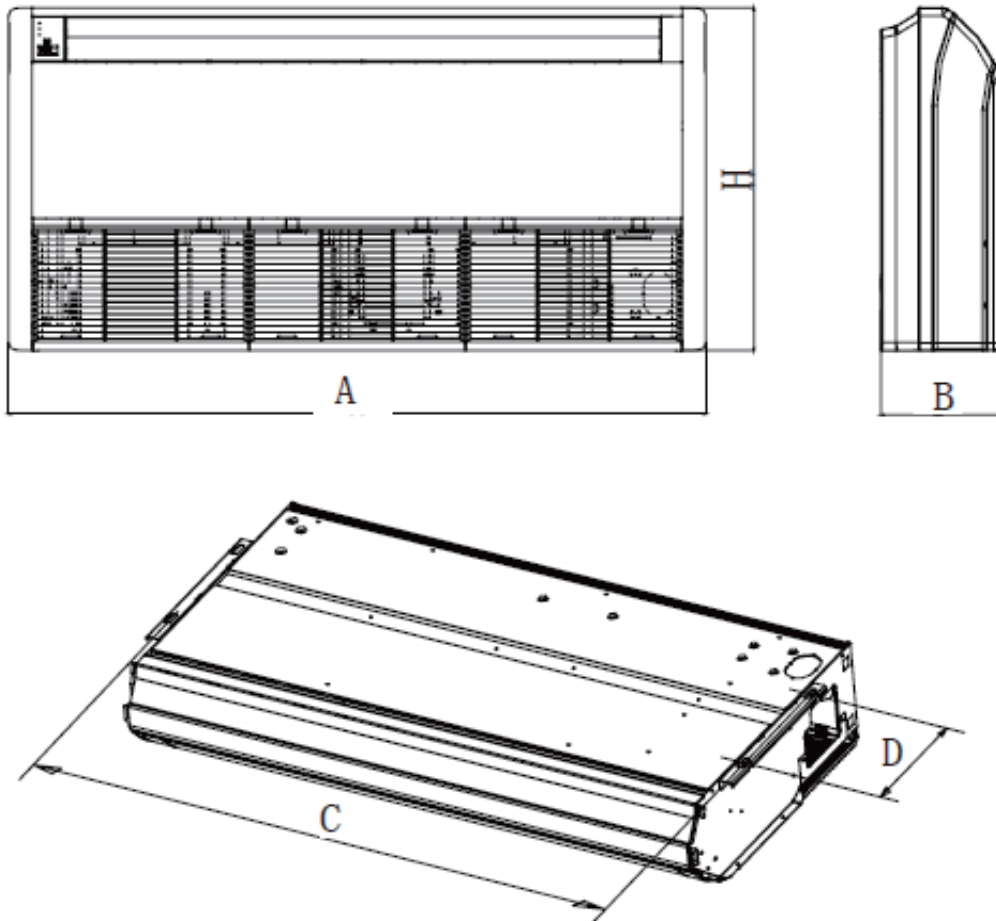

Model	A	B	H	C	D
KM09HTDI	1220	225	700	1158	280
KM12HTDI					
KM18HTDI					
KM24HTDI					

Installation and Servicing Space

The space around the unit is adequate for ventilation.