

MOVEX®

LF



Portable filter with numerous areas of use and flexible solutions for temporary work.

Movex LF is an effective and flexible solution including a fan and filter in a single unit.

LF includes a FF 100 fan with a highly-efficient EC motor, equipped with speed control as well as a filter. The filter comes in two designs and in two sizes - combined particle/gas filter or gas filter.

LF is available as a complete kit solution, in six designs for simple selection and installation.

The FF 100 fan can be used separately or in combination with Movex series laboratory extractors.

The Movex range also includes fans, accessories, automatic controls and filters suitable for local extraction.

MOBILE FILTER
Pure advantages

MOVEX^{LF}

Complete LFK kits for flexible solutions and simple installation.

All kits come complete with hoses, connectors and accessories. Each arm is equipped with a damper for individual airflow adjustment. The FF 100 fan has an EC motor with potentiometer for speed control, which makes it easy to continuously adjust the ventilation according to airflow requirements.

LFK 150

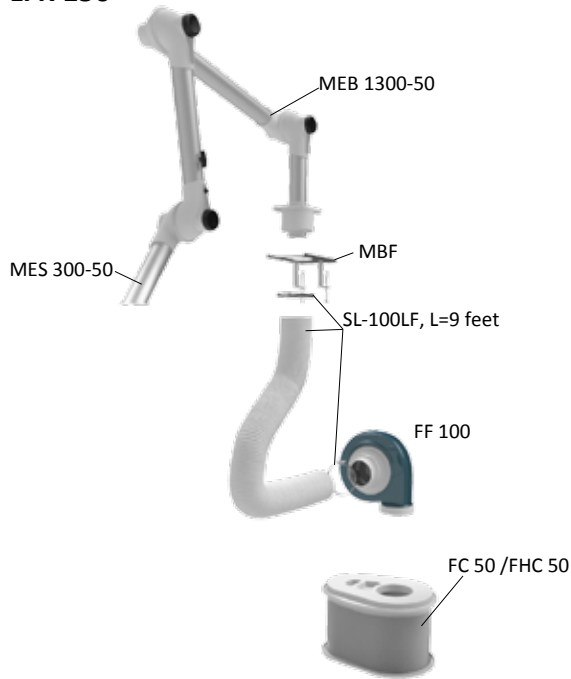

LFK 250

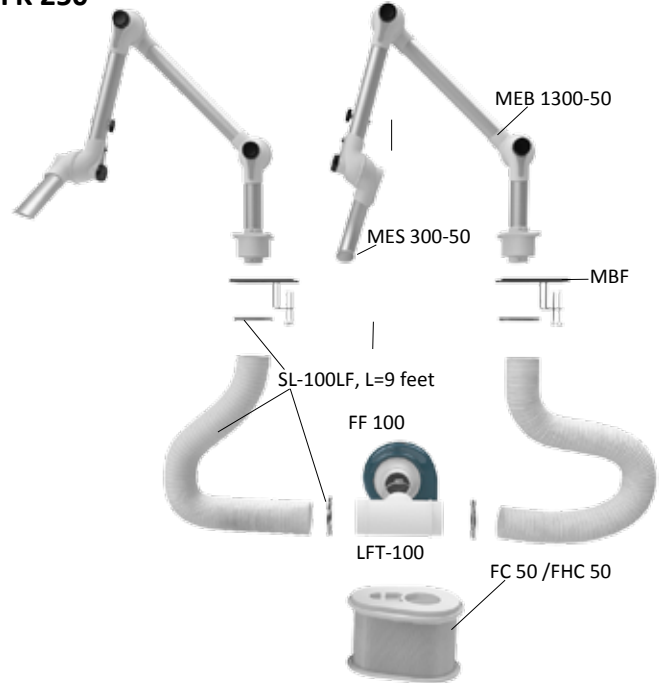

LFK 450

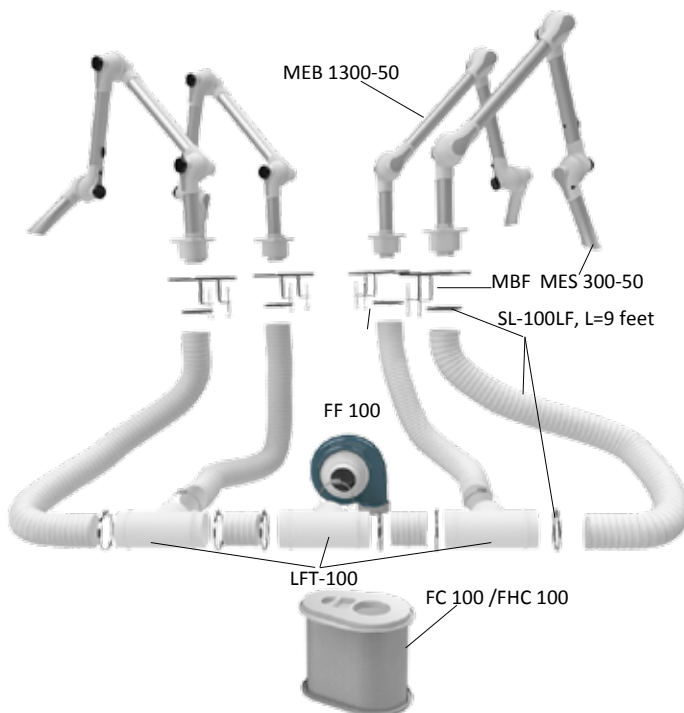

LFK 350C

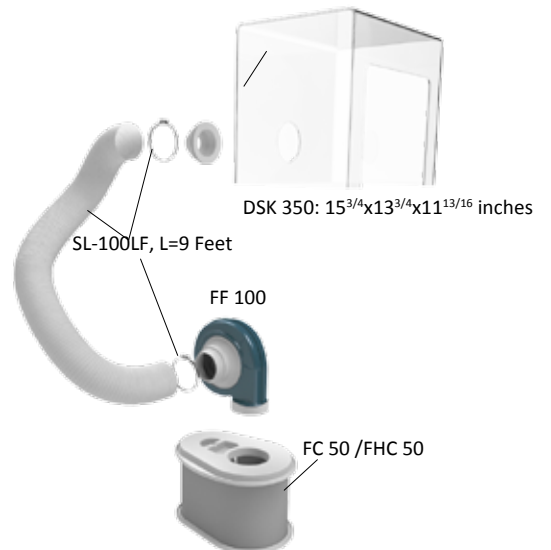

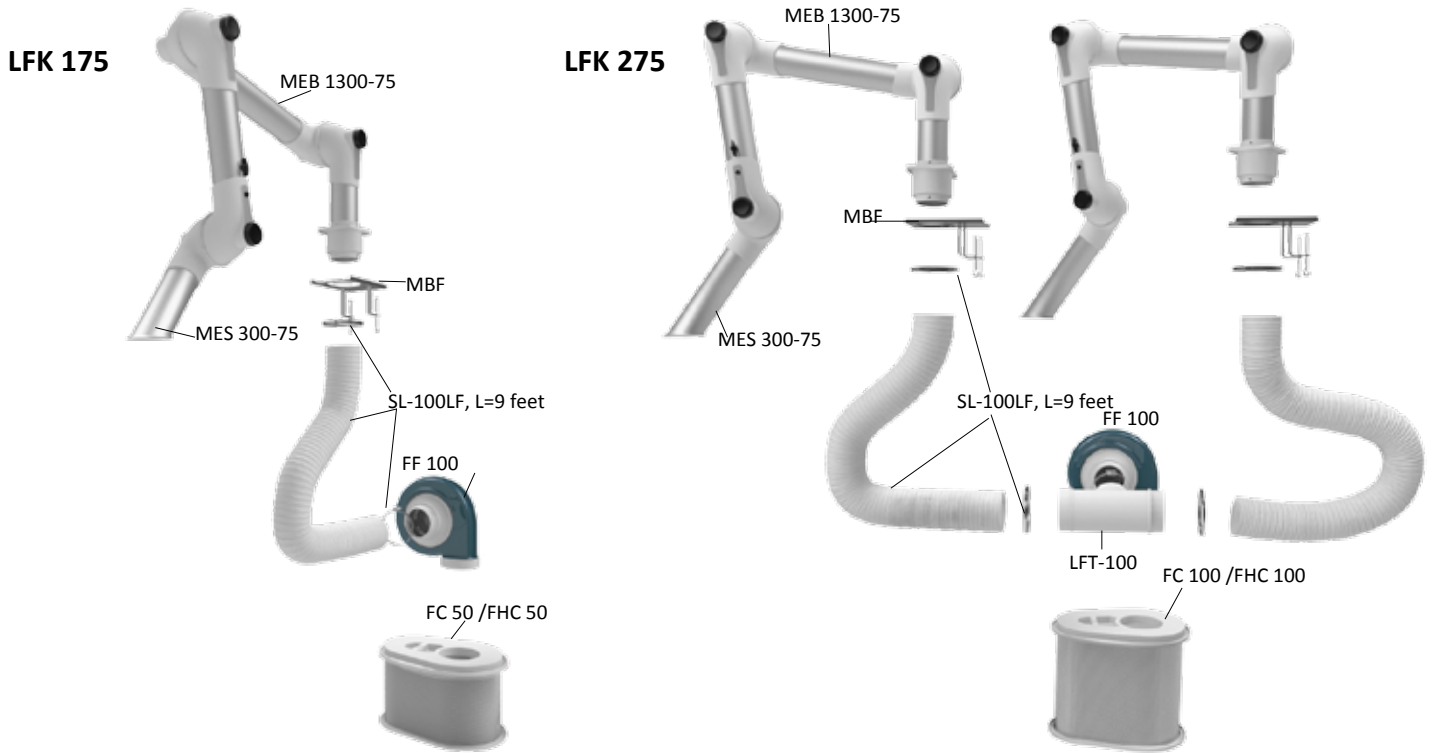

Our LFK kits contain ME arms with low pressure drop and high flexibility

Lowest possible pressure drop is a quality aspect that always should be considered.

With its uniquely designed joint construction, Movex ME combines maximum flexibility with low pressure drop. The air passes through the joints without creating unnecessary turbulence, thus producing an energy-saving low pressure drop and a quieter working environment.



**SPEED CONTROL FAN**Part.nr: **FF 100/230**Part.nr: **FF 100/115**

The efficient EC motor with integrated speed control allows for variable airflow. The fan's optimised design provides superior performance with maximum pressure. Connects easily to single-phase electrical connectors. Can also be used as a separate unit in combination with wall-bracket LF VK and Movex series laboratory arms. FF 100 available for 200-240V, 50-60Hz or 100-130V, 50-60Hz.

**PORTABLE FILTER UNIT WITH FAN**Part.nr: **LF 50PG/230** Particle/Gas filterPart.nr: **LF 50G/230** Gas filterPart.nr: **LF 50PG/115** Particle/Gas filterPart.nr: **LF 50G/115** Gas filterPart.nr: **LF 100PG/230** Particle/Gas filterPart.nr: **LF 100G/230** Gas filterPart.nr: **LF 100PG/115** Particle/Gas filterPart.nr: **LF 100G/115** Gas filter

A portable filter with an LF 100 fan that produces a low noise level and allows for variable airflow. The filter is either a Particle/ Gas filter or solely a Gas filter and can be easily adapted according to your needs.

**PARTICLE/GAS FILTER**Part.nr: **FHC 50**Part.nr: **FHC 100**

A two stage filter that separates dust and fume particles with the initial HEPA section. This is followed by a Activated Carbon filter for absorption of VOCs, gases and odors.

FHC 50 Hepafilter/H 13* Gas filter/Activated carbon filter 4.4 lb

FHC 100 Hepafilter/H 13* Gas filter/Activated carbon 9 lb

**Filter efficiency for a H13 filter is 99.99% for 0.3 µm particles*

**GAS FILTER**Part.nr: **FC 50**Part.nr: **FC 100**

A high capacity filter for applications needing gas filtration only. The high quality granulated activated carbon is suitable for the absorption of VOCs, gases and odors.

FC 50 Gas filter / 14 lb

FC 100 Gas filter / 33 lb

BRACKET

Part.nr:
LF VK

Compatible with the FF
100 fan, for wall or ceiling
mounting.



VTA ADAPTOR

Part.nr:
LF VTA

A specially designed sleeve to enable the filtered air to be
vented to atmosphere, or connection to a existing duct
system. Only available for FC 50 / FHC 50



DOME HOOD

Part.nr:
MEK 350-50 (Ø2")
MEK 350-75 (Ø3")

The clear dome hood is suitable for lighter gasses with a wider
dispersal of contaminants without blocking the user's vision.



FLAT SCREEN HOOD

Part.nr:
MEPH 300-50 (Ø2")
MEPH 300-75 (Ø3")

The flat screen hood is designed to maximize the working area
without obscuring the object from the user. The flat screen hood
gives the best suction effect for table and bench tasks.



SQUARE HOOD

Part.nr:
MESH 350-50 (Ø2")
MESH 350-75 (Ø3")

The square hood is suitable for placing above gases with a high lift,
or adjacent to the work surface for contaminants with no lift or
low lift – all this without interfering with the work.



FLEXIBLE SUCTION NOZZLE

Part.nr:
MEFS 600-50 (Ø2")
MEFS 600-75 (Ø3")

The flexible suction nozzle is designed to maximize ease of
movement without sacrificing air flow efficiency. Available in the
ESD version only.



MOVEX[®] LF

Health aspects

Particles from fume and dust.

Some particles from substances such as quartz can enter and remain in the lungs. Other particles can enter the blood stream and are transported to other organs and areas of the body. If the fume for instance includes lead the particles can enter the alveolus in the lungs and then transferred to the blood stream and can be transported to the skeleton.

Vapor from solvents (VOC).

Nearly all solvents are Volatile Organic Compounds or liquids. They are used in a many every day applications, such as component cleaning, degreasing, and to dissolve products that are not able to be dissolved in water. They also form the drying agent in products such as adhesives, paints, and varnishes. Vapors from these solvents typically have a narcotic effect that courses tiredness, dizziness and intoxication. Vapor and gases from solvents can also enter your body by the respiratory system and then spread to the brain and liver. The vapors from solvents are also irritating your eyes and respiratory system.

Save your lungs!

By using a suitable and effective extraction solution combined with an efficient filter system, you can reduce or even eliminate the risk of working with airborne hazards.

Particles smaller than 5 µm enter your lungs through the alveolus and can harm you in a many ways. It is best practice to prevent the airborne hazard entering the breathing zone by capturing it at source.

Application guide line

Type of application	Hazard substances	Rec. LFK	Rec. filter
Soldering (Electronic)	Resin, Lead, Terpene, Limonene, Borneol, Isosyanates	LFK 150/250/450	Particle/Gas
Solder Pot	Resin, Lead, Terpene	LFK 175/275	Particle/Gas
Gluing / Bonding	VOC1, Methylmetacrylate (MMA), Toluene, Ethyl-2-cyanoacrylate, Tetrahydrofuran, Cyklohexanone	LFK 150/175	Gas
Screen printing	Methyl ethyl ketone (MEK), Toluene	LFK 150/250	Gas
Cleaning / degreasing	Acetone, Toluene, MEK, VOCs1	LFK 350 C	Gas
Dental Lab	Dust, MMA	LFK 175/275	Particle/Gas
Nail salon	2-Hydroxyethyl methacrylate (HEMA), MMA, Acetone, buffing dust	LFK 150	Particle/Gas
Laser cutting	Dust, metal particulate, odor	LFK 150/450	Particle/Gas
Moulding	Epoxi, Styrene	LFK 175/275	Gas
Conservation	VOCs1	LFK 175/275/LFK 350C	Gas
Precision TIG welding	Welding fume, Gases, Ozone	LFK 175/275	Particle/Gas
Stained Glass working	Lead fume, VOCs1	LFK 175/275	Particle/Gas
Botany research	VOCs1	LFK 175/275	Gas
Sculpturing	VOCs1, silica dust, sealants	LFK 150/175/275	Particle/Gas

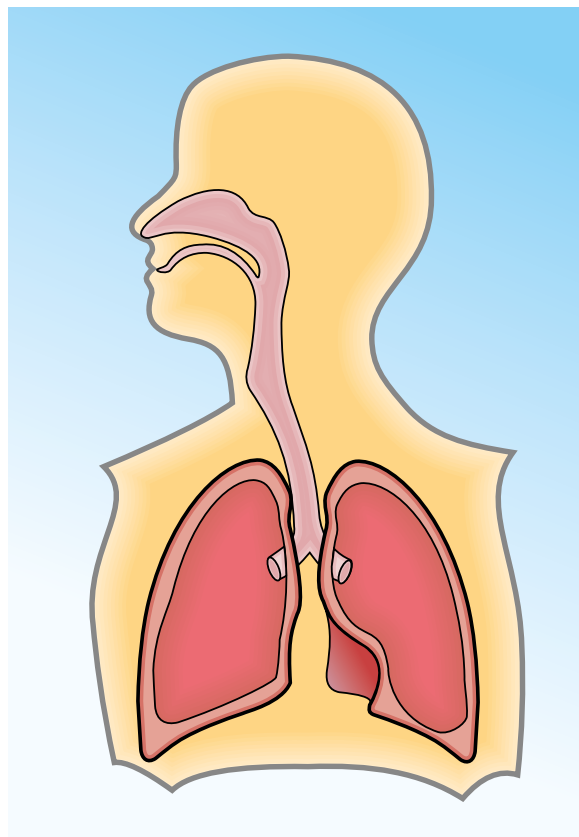

MOVEX LF

FF 100

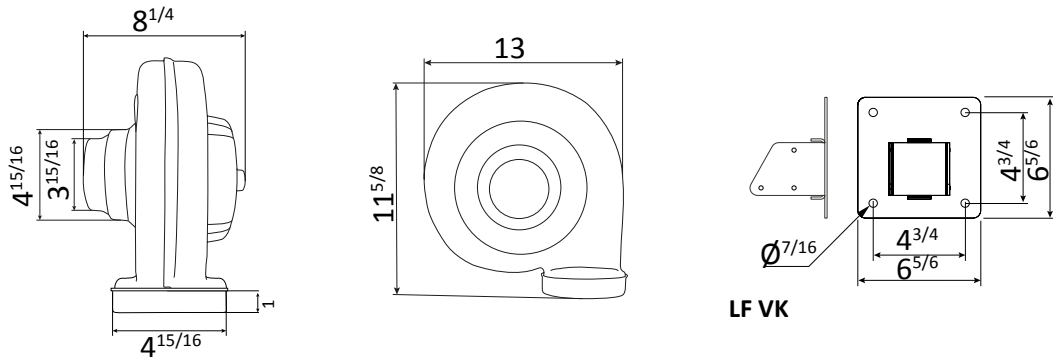

FF 100 +
FC/FHC 50

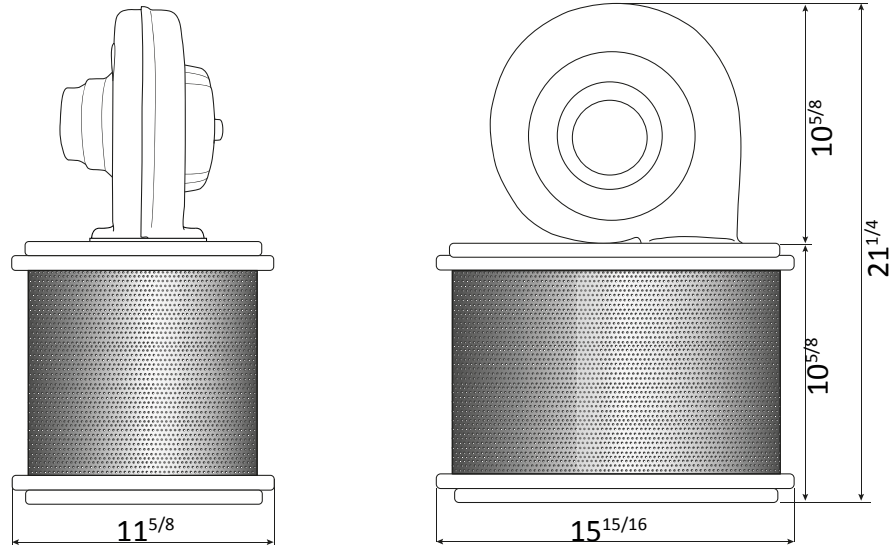

FF 100 +
FC/FHC 100

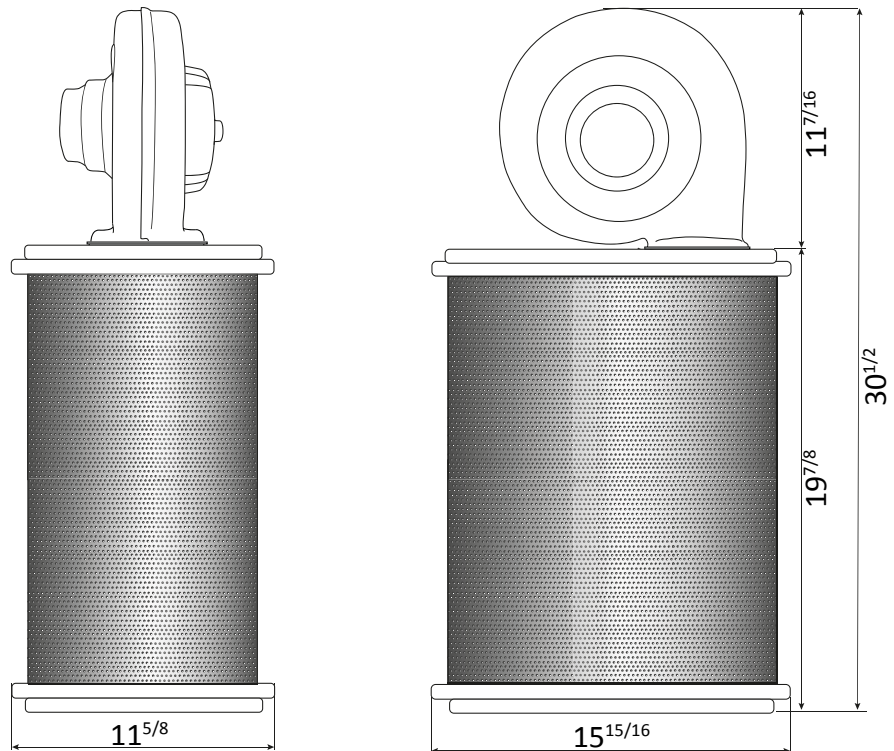

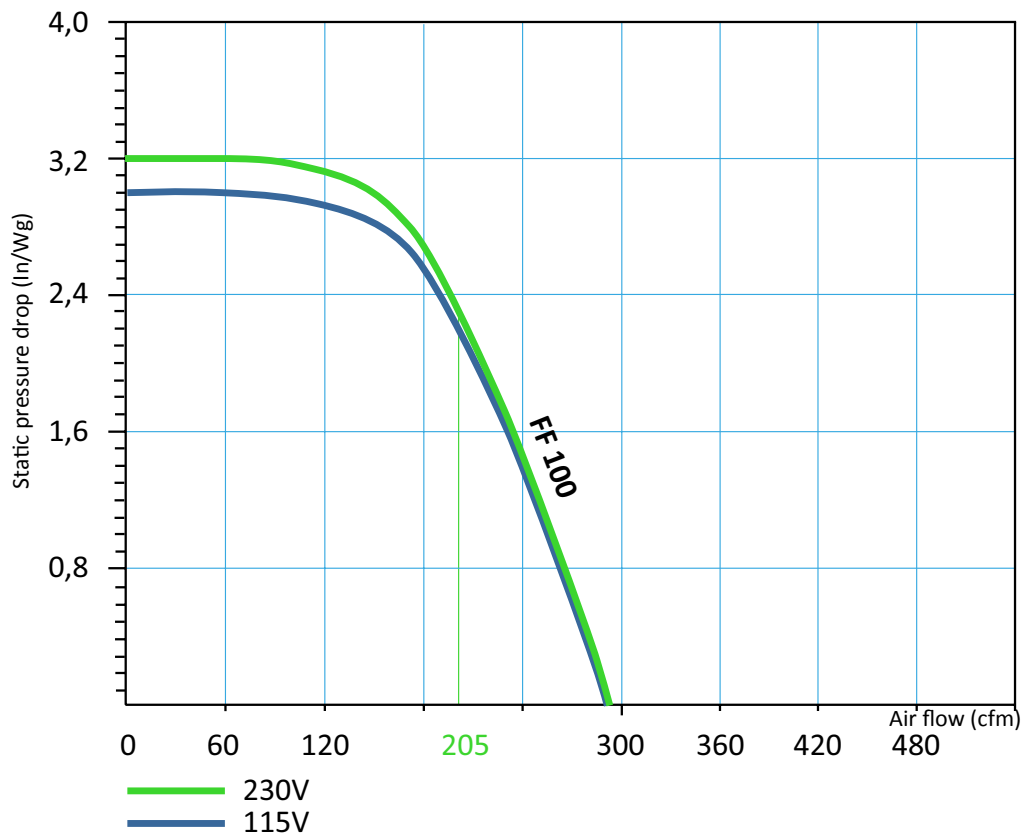

Performance FF 100

Airflow	0-210 cfm (max)
Motor 230V	0.22 hp, 200-240V / 50-60 Hz
Motor 115V	0.19 hp, 100-130V / 50-60 Hz
Weight	7 lb
Noise level (1 m)	60 dB(A)
Max temperature	120°F

MOVEX®

104 Commerce Drive, Northampton, PA 18067, USA
 Phone: 610 440-0478, Fax: 610 440-0480
www.movexinc.com info@movexinc.com